

## Technical Data Sheet

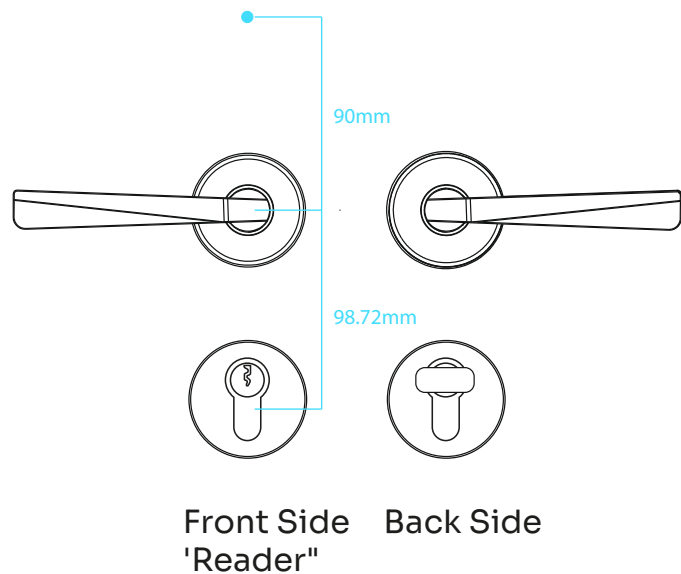

Power	4 x AA battery (TLJ batteries recommended)
Material	Zink Alloy & Polycarbonate Stainless steel SUS304
Metal Finishes	Satin Chrome (SR) . Polished Chrome (PC) Satin Gold (SG) . Polished Gold (PG)
Battery Location	Within the lockcase, housed inside the door
Emergency Open	Mechanical over-ride cylinder, physical key
Operating Temp	-20°C to 70°C
Certifications	EN14846 - Mechanical load & cycle testing EN1634-1 - Fire tested to FD30 & FD60 doors EMC, R&TTE & LVD Directives PAS24 - Physical attack security test CE Marked CertiFire TS81
Privacy Bolt	Hardened with anti drill pins

Lockcase

European - EURINV/377  
60mm Backset

